

**CONCEPTUAL UTILITIES  
FOR  
REGIONAL GATEWAY COMMERCE PARK  
I-10 & I-8 INTERCHANGE  
CASA GRANDE, AZ**

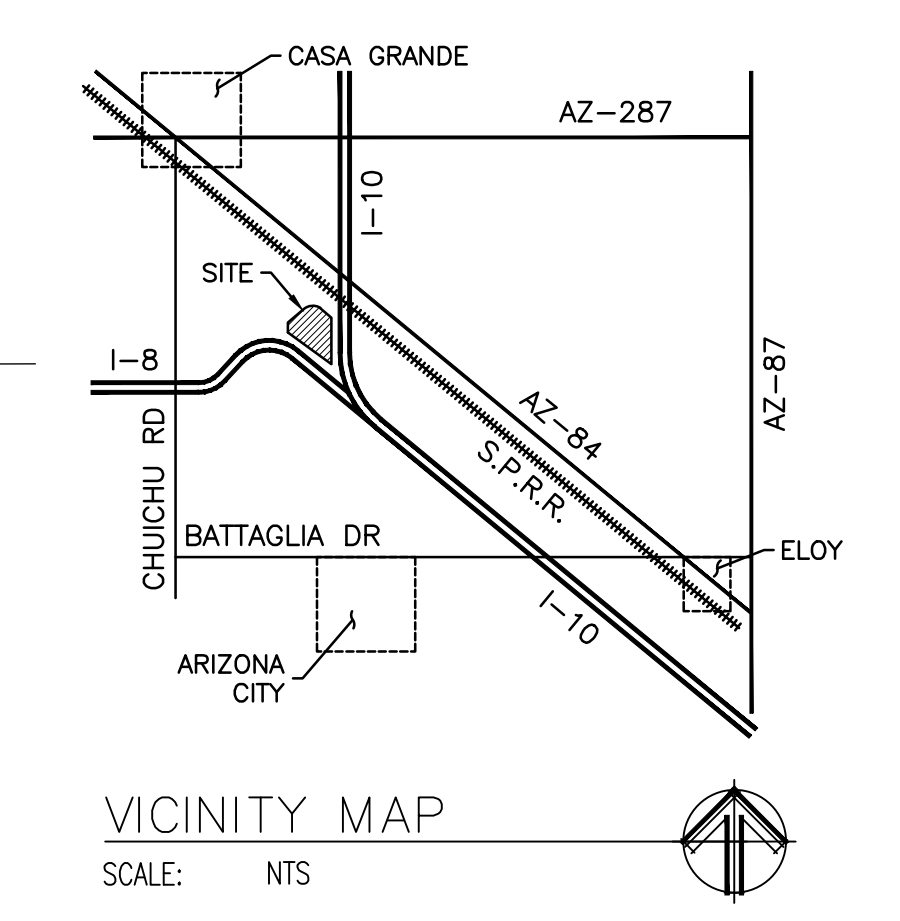

**DEVELOPER**  
CHASSE R.E. & FINANCIAL GROUP  
P.O. BOX 15267  
PHOENIX, AZ 85060  
CONTACT: GEORGE CHASSE, SR.

**ENGINEER**  
CEG, INC.  
P.O. BOX 2368  
GLENDALE, AZ 85311  
623.536.1993  
CONTACT: NATE COTTRELL

**LEGEND:**

- LIMITS OF CURRENT DEVELOPMENT
- EXISTING WATER LINE
- EXISTING SEWER LINE
- NEW 12" DIP WATER LINE
- FUTURE 12" WATER LINE CONNECTION
- NEW 15" PVC SEWER LINE
- NEW 8" PVC SEWER LINE

**REGIONAL GATEWAY COMMERCE PARK  
CONCEPTUAL UTILITIES**

I-10 & I-8 INTERCHANGE  
CASA GRANDE, AZ

DRAWN BY:	NEB
CHECKED BY:	NJC
DATE:	09/04/13
SCALE:	1" = 500'
PROJECT #:	12-121
LAST MODIFIED:	
LAST MODIFIED BY:	

**P.O. BOX 2368  
GLENDALE, AZ 85311  
PH: (623) 536-1993**

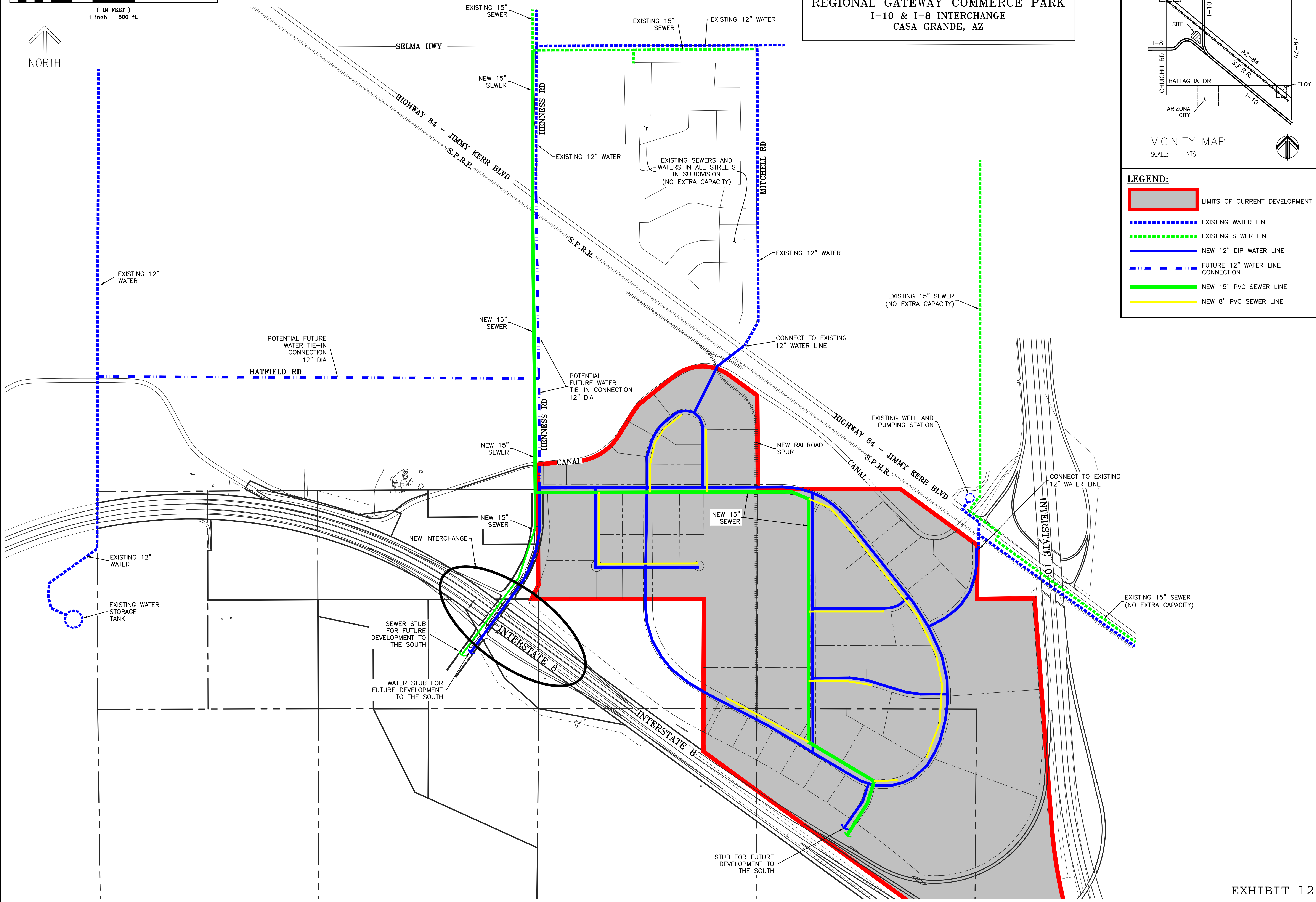

EXHIBIT 12

CASA GRANDE MTN. RANCH 12-121 CITY#